



(RESEARCH ARTICLE)



Numerical Study of Von Kármán Vortex Streets Inside Heat Exchangers

Stanley A. Omenai *

Department of Mechanical Engineering, Georgia Institute of Technology, Atlanta, USA.

International Journal of Science and Research Archive, 2024, 13(02), 2504–2518

Publication history: Received on 31 October 2024; revised on 05 December 2024; accepted on 07 December 2024

Article DOI: <https://doi.org/10.30574/ijrsra.2024.13.2.2444>

Abstract

This study highlights the occurrence of vortex shedding for flow around a bluff cylindrical object for Reynold's number between 500 and 1400.

Using a heat exchanger model with a single tube, the vortex shedding in the wake of the cylindrical tube is numerically studied for various Reynold's number. The shedding frequency is also determined and the Strouhal number, St , computed. The values of Strouhal numbers obtained are found to compare with those found in literature.

The presence of lift and drag forces, which occurs as a result of the vortex shedding are also observed. These can lead to catastrophic vibrations in the tubes when the vortex shedding frequency resonates with the natural frequency of the tubes.

The effects of variation of fluid properties due to temperature on vortex shedding and shear stress are also studied.

Finally, a characteristic tube bank is used to study the damping effects created by adjacent tubes in a typical heat exchanger tube array.

Keywords: Von Kármán; Vortex Shedding; Reynold's Number; Strouhal Number; Bluff Cylinder; Baffle

1. Introduction

In fluid mechanics, vortex shedding is an oscillating flow pattern that takes place when a fluid such as air or water flows past a bluff body at certain velocities, depending on the size and shape of the body. During such flows, vortices are created behind the body and detach periodically from either side of it, thus forming a Von Kármán vortex street. The fluid flow past the object creates alternating low-pressure vortices on the downstream side of the object. The object will tend to move toward the low-pressure zone.

1.1. Problem description

Shell and tube heat exchangers are ubiquitous and are commonly used in the energy industry, with hundreds to even thousands of tube bundles inside each heat exchanger.

Cross flow heat exchangers are a special class of shell and tube heat exchanger, where the fluid inside the shell moves perpendicularly to the tube bank so vortex shedding may occur. This introduces vibrations inside the heat exchanger that limits the overall performance.

* Corresponding author: Stanley a. Omenai

The purpose of this project is to numerically study the effect of the Von Kármán vortex street in an idealized flow around an infinite cylinder in terms of velocity, vortex formation, pressure, lift and drag forces.

The effects of material property variation and temperature effects shall then be analyzed with respect to the flow parameters above.

Finally, the study shall be expanded to include a characteristic tube bank to analyze the damping effect created by adjacent tubes in typical heat exchangers with array of tubes.

2. Literature review

Von Kármán vortex street is a repeating pattern of swirling vortices, caused by a process known as a vortex shedding, which is responsible for the unsteady flow separation of a fluid around blunt bodies as shown below:

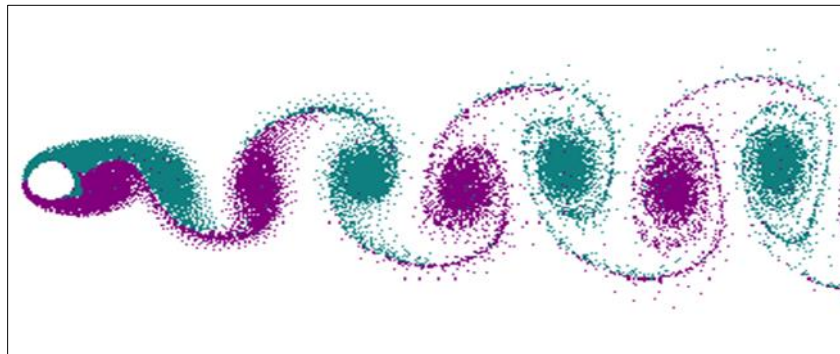

Figure 1 Vortex Street created by a cylindrical object; the flow on opposite sides of the object is given different colours, showing that the vortices are shed from alternating sides of the object.

2.1. Vortex shedding behind a circular cylinder

The periodic vortex shedding behind a cylinder immersed in a steady freestream have an oscillatory pattern which is dependent on Reynolds number. The figure below shows a sketch of the vortex formation behind a circular cylinder.

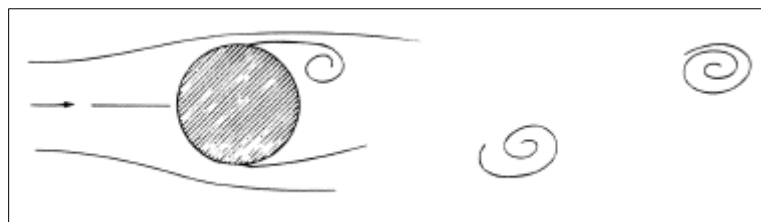

Figure 2 Vortex formation behind a circular cylinder.

It can be seen that a vortex is in the process of formation near the top of the cylinder surface while below and to the right of the first vortex is another vortex which was formed and shed a short period before. Thus, the flow process in the wake of a cylinder or tube involves the formation and shedding of vortices alternately from one side and then the other.

This phenomenon is of major importance in engineering design because the alternate formation and shedding of vortices produces a sinusoidal force acting on the body perpendicular to the flow, which occur more frequently as the velocity of the flow increases.

When the frequency is in the audible range, a sound can be heard, and the body appears to sing. Resonance may also occur if the vortex shedding frequency is near the structural-vibration frequency of the body.

A dimensionless number, the Strouhal number St , is commonly used as a measure of the predominant shedding frequency f , defined as;

$$St = \frac{fD}{U_{\infty}}$$

where D is the diameter of the circular cylinder and U_{∞} the freestream velocity.

The Strouhal number of a stationary tube or circular cylinder is a function of Reynolds number but less of surface roughness and freestream turbulence. It is found that the Strouhal number is about 0.2 over a large Reynolds number interval^[1].

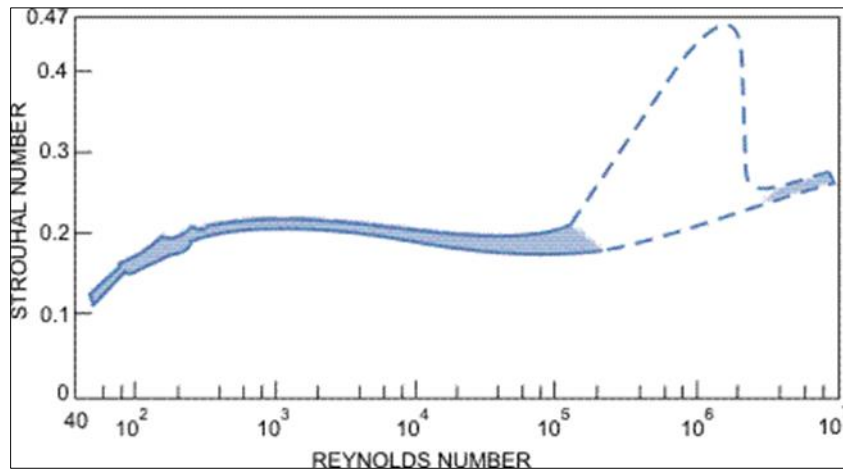

Figure 3 Strouhal number versus Reynolds number for circular cylinders (tubes). From Blevins R. D. (1990) Flow Induced Vibrations, Van Nostrand Reinhold Co [1].

Vortex shedding also occurs from pair of cylinders, multiple cylinders, arrays of cylinders and heat exchanger tube bundles. However, the pitch-to-diameter ratio (centre-to-centre distance divided by tube diameter) is important. For two cylinders, placed in-line, vortex shedding occurs behind each cylinder separately if the pitch-to-diameter ratio exceeds a certain value while for smaller values, the two cylinders behave as a single body in terms of vortex shedding.

2.2. Vibrations in heat exchangers

Vibration of tubes in heat exchangers is an important limiting factor in heat exchanger operation. The vibration is caused by nonstationary fluid dynamic processes occurring in the flow. These include turbulent pressure pulsations, vortex initiation and separation from tubes in crossflow, hydro elastic interaction of heat transmitting element (tubes) assemblies with the flow, and acoustic phenomena.

The most common mode of vibration in shell and tube heat exchangers is as a result of vortex shedding on the tubes. If the frequency of the shed vortices is the same as one of the natural frequencies of the structure, then large vibrations can result.

In calculating tube vibration, it is important to find the natural frequency of vibration of the tubes. The natural frequency of vibrations depends on both the mode shape and the physical characteristics of the tube, and the way its ends are fixed.

Although it is possible for vortex-induced vibrations to cause the structure to fail through the ultimate load being exceeded, failure is more likely to occur through fatigue.

Among the whole tube-like structures, vortex-induced vibration could be prominent in the cases of a single tube and tube arrays with large pitch-to-diameter ratio (P/D) values. In the case of tube arrays with small P/D values, the instability behaviors are often caused by fluid-elastic instability.

Gelbe et al. ^[2] pointed out that undisturbed Karman vortex streets can only develop when large pitch-to-diameter ratios (P/D) are involved, and vortex formation is impeded by neighboring tubes with small P/D , that is, $1.1 < P/D < 2.0$. According to their view, the effect of neighboring tubes on vortex formation can become increasingly weaker as the P/D

value increases. As a result, the vortex-induced vibration behaviors of tube arrays with too large P/D can be quite similar to those observed for an isolated tube.

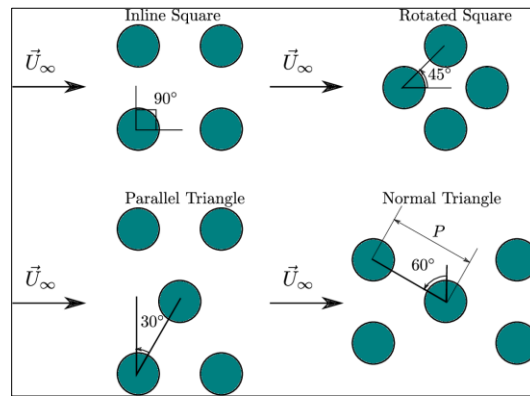

Figure 4 Commonly used array geometries in heat exchangers.

Strouhal numbers depend on the position of the tube in the bundle and on the existing flow conditions (turbulence, Reynolds number, acoustic resonance) [3].

Strouhal numbers for the normal triangular arrays generally increase with decreasing pitch ratio.

2.3. Minimizing vibrations in shell and tube heat exchangers

To design an exchanger without vibration issues, a designer has to be aware of many parameters that can independently, or in conjunction with other parameters, affect the vibration analysis. The parameters listed below are critical in vibration analysis and manipulating these parameters might reduce or produce vibration significantly. Most of the parameters that are required to be altered to mitigate vibration would also affect thermal performance. Hence, thermal, and vibrational analyses need to be done together to ensure proper design [4].

2.4. Use of Baffles/Support Plates

The unsupported span of tubes in a heat exchanger has significant impact on vibration analysis. Introducing segmental baffles in heat exchanger design helps to minimize vibrations. However, the use of multi-segmental baffles reduces the crossflow velocity.

It may be useful to provide partial support plates at the entrance/exit areas to reduce unsupported tube spans and vibration.

2.5. Use of Impingement Devices at Entrance/Exit Areas

Entrance and exit areas are generally more susceptible to damage from vibration. To avoid damage due to erosion and vibration at these areas, it may be required to also provide an impingement device.

Rod-grid impingement devices provide a more uniform velocity profile across the entrance of the exchanger, resulting in a lower pressure drop and reducing velocity transients that can lead to vibration.

2.6. Omission of Tubes at Critical Locations

Limiting the bundle entrance/exit momentum helps in minimizing vibration issues. This can be achieved by removing tube rows under the nozzles that are most susceptible to vibration.

Similarly, at predetermined critical locations in a bundle, the potential for vibration can be reduced if tubes are not installed at those places. Omitting tubes along the baffle cut line may help in reducing vibration.

2.7. Tube Pitch/Layout Pattern

The tube pitch is a very important parameter that can help in reducing vibration. Tube pitch-diameter ratios in the range $1.1 < P/D < 2.0$ result in reduced crossflow velocity. As a consequence, flow-induced vibrations are lower.

The tube layout pattern is also one of the parameters that could help in reducing vibration. The triangular layout pattern is particularly useful in cases where vibration occurs due to fluid-elastic instability.

2.8. Tube Material

The elastic modulus of the tubes affects the natural frequency of an unsupported tube span. A higher elastic modulus provides greater resistance to vibration tendencies. Ferritic or austenitic stainless steel alloys have greater elastic moduli than materials like aluminum or brass. However, the service and the nature of the fluid in the tubes is key in material selection.

2.9. Tube Diameter

Larger tube diameters result in less vibration issues, as the increased moment of inertia of such tubes provides greater stiffening of tubes for a given length. However, the economics, hydraulic feasibility and impact on thermal design must be considered.

2.10. Use of Anti-Vibration Technologies

Several proprietary anti-vibration technologies are available to mitigate vibration issues. These are particularly useful to handle vibration problems in existing exchangers, as they allow flexibility to retain the same exchanger geometry. One such example is the use of dimpled or saddled tube supports. The strips are inserted into the affected vibration area. The tubes and strips will automatically lock each other into place. As a consequence, the bundle stiffens and reduces the potential for vibration.

3. Governing equations and boundary conditions

The equations governing incompressible viscous fluid flow in two-dimensions are the continuity equation, the two components of momentum equation and energy equation. In absence of body forces and viscous dissipation, these equations can be expressed as follows:

Continuity Equation:

$$\frac{\partial u}{\partial x} + \frac{\partial v}{\partial y} = 0$$

X-Momentum equation:

$$\frac{\partial u}{\partial t} + u \frac{\partial u}{\partial x} + v \frac{\partial u}{\partial y} = -\frac{\partial P}{\partial x} + \nu \left(\frac{\partial^2 u}{\partial x^2} + \frac{\partial^2 u}{\partial y^2} \right)$$

Y-Momentum equation:

$$\frac{\partial v}{\partial t} + u \frac{\partial v}{\partial x} + v \frac{\partial v}{\partial y} = -\frac{\partial P}{\partial y} + \nu \left(\frac{\partial^2 v}{\partial x^2} + \frac{\partial^2 v}{\partial y^2} \right)$$

Energy equation:

$$\frac{\partial T}{\partial t} + u \frac{\partial T}{\partial x} + v \frac{\partial T}{\partial y} = \alpha \left(\frac{\partial^2 T}{\partial x^2} + \frac{\partial^2 T}{\partial y^2} \right)$$

The following boundary conditions are used.

At the inlet:

$u = U_0$, where U_0 is the prescribed flow velocity for the specific simulation case

$T = T_\infty$, where $T_\infty = 300\text{K}$

At the circular obstacle:

$u = v = 0$, no slip condition

$T = T_0$, where T_0 is the prescribed cylinder surface temperature for the specific simulation case

At the walls:

$u = v = 0$, no slip condition

$T = T_\infty$, where $T_\infty = 300\text{K}$

At the exit:

$P = P_\infty$, where P_∞ is ambient pressure (1 atm or 0 barg)

4. Numerical methodology

4.1. Geometry

ANSYS geometry editing software "DesignModeler" was used to design the computational domain. The 2-D cylinder is represented as a circle with a diameter of 2cm with the center located on the origin of the plane. The upstream and downstream lengths of the domain are 10D and 20D respectively & this distance is computed from the center of the circle. the downstream distance has been kept longer to capture the flow physics: in this case, the vortex formation.

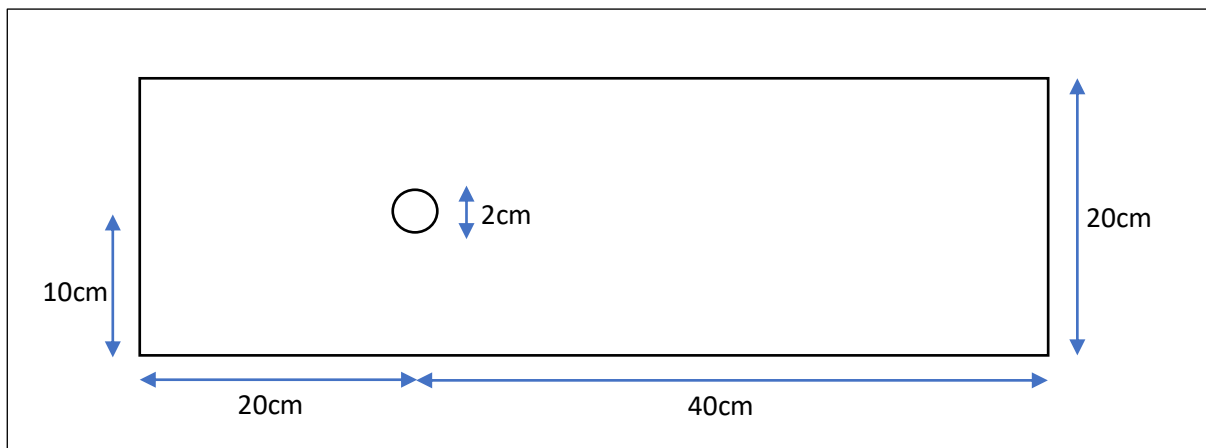

Figure 5 Domain for flow around an infinite cylinder

In part 4, additional tube banks with a pitch-to-diameter ratio of 1.732 are included in the geometry as specified below.

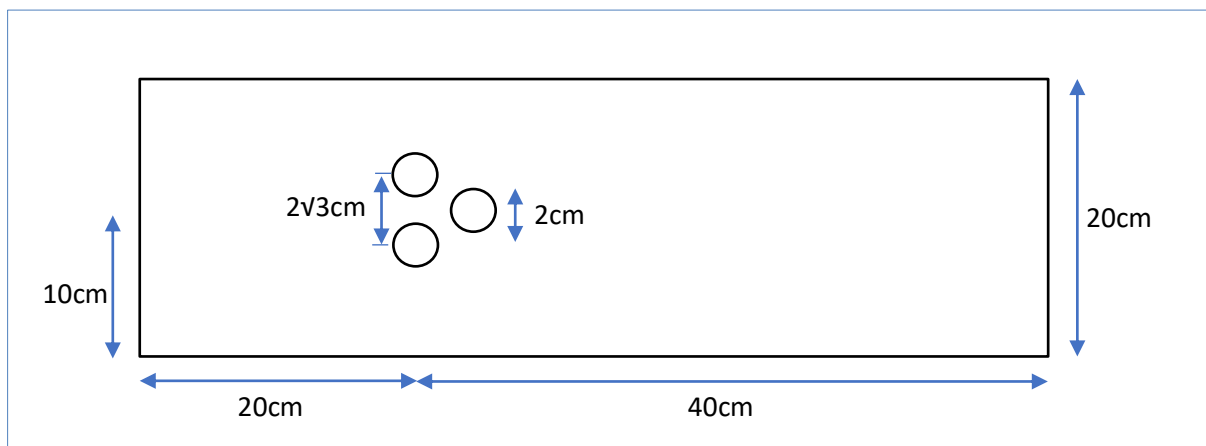

Figure 6 Domain for flow around a characteristic tube bank

4.2. Meshing

In the ANSYS mesh module, the entire geometry surface is discretized using triangular mesh. The edge of the circle is refined to remove sharp corners. Thereafter, 10 inflation layers, with a growth rate of 1.2 are included where the fluid entering the domain will interact. This is to correctly capture the velocity and temperature gradients near no-slip walls.

Finally, the boundaries for the geometry are specified: inlet, outlet, symmetric walls & stationary walls.

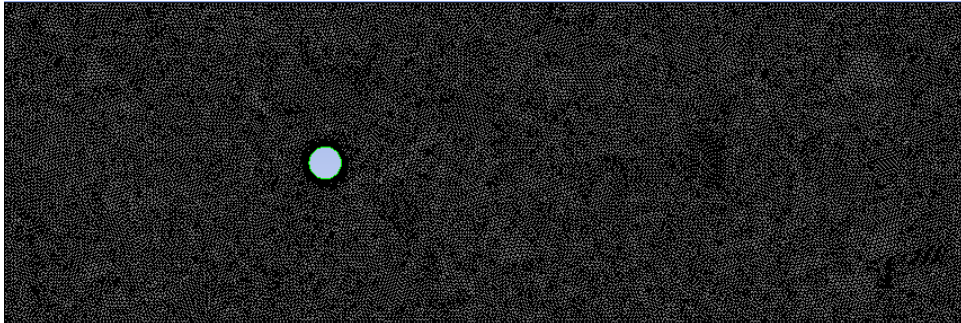

Figure 7 Mesh for flow around infinite cylinder

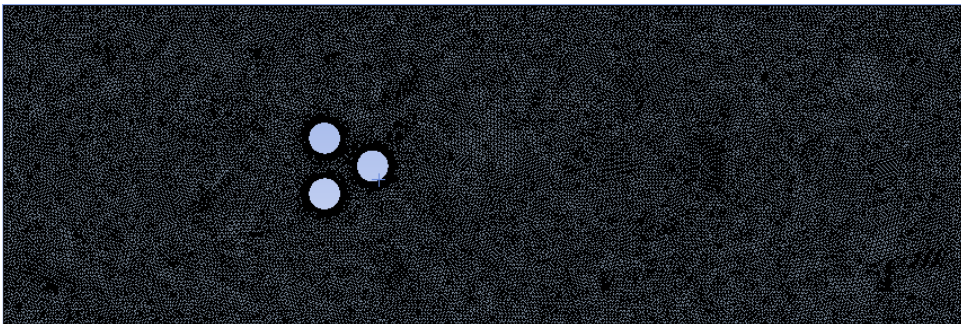

Figure 8 Mesh for flow around characteristic tube bank

4.3. Flow physics

The following flow parameters in table 1, were specified using ANSYS Fluent.

Table 1 ANSYS Flow Parameters

SOLVER	Pressure Based, Transient
FLOW TYPE	Viscous Laminar
FLUID TYPE	Water
DENSITY (kg/m ³)	998.2
VISCOSITY (kg/m-s)	0.001003
CYLINDER MATERIAL	Aluminium
WALL MATERIAL	Aluminium
INITIALIZATION	Hybrid
NUMBER OF TIME STEPS	500
TIME STEP SIZE	0.1
MAX. ITERATIONS PER TIME STEP	20

The inlet velocity is specified for different simulations corresponding to Reynold’s numbers in the range 500 – 1400.

For part 3, the energy equation is turned on and a constant cylinder temperature of 400K is imposed on the surface for flow at Reynold’s number of 1000.

The properties of water (viscosity, specific heat capacity and thermal conductivity) are also set to vary with temperature using the in-built kinetic theory model in FLUENT. The flow is considered incompressible since the Mach number is less than 0.3, hence, density was kept constant.

5. Results and discussions

The mesh statistics is provided in table 2 below:

Table 2 Mesh Statistics

Mesh Details	
Mesh Type	Triangular
Element Size	0.002
Nodes	32817
Number of Elements	63756
Cylinder Edge Sizing	
Number of Divisions	100
Number of Inflation Layers	10
Transition Ratio	0.272
Growth Rate	1.2

The plot of residuals at steady state showing convergence after 315 iterations is provided below:

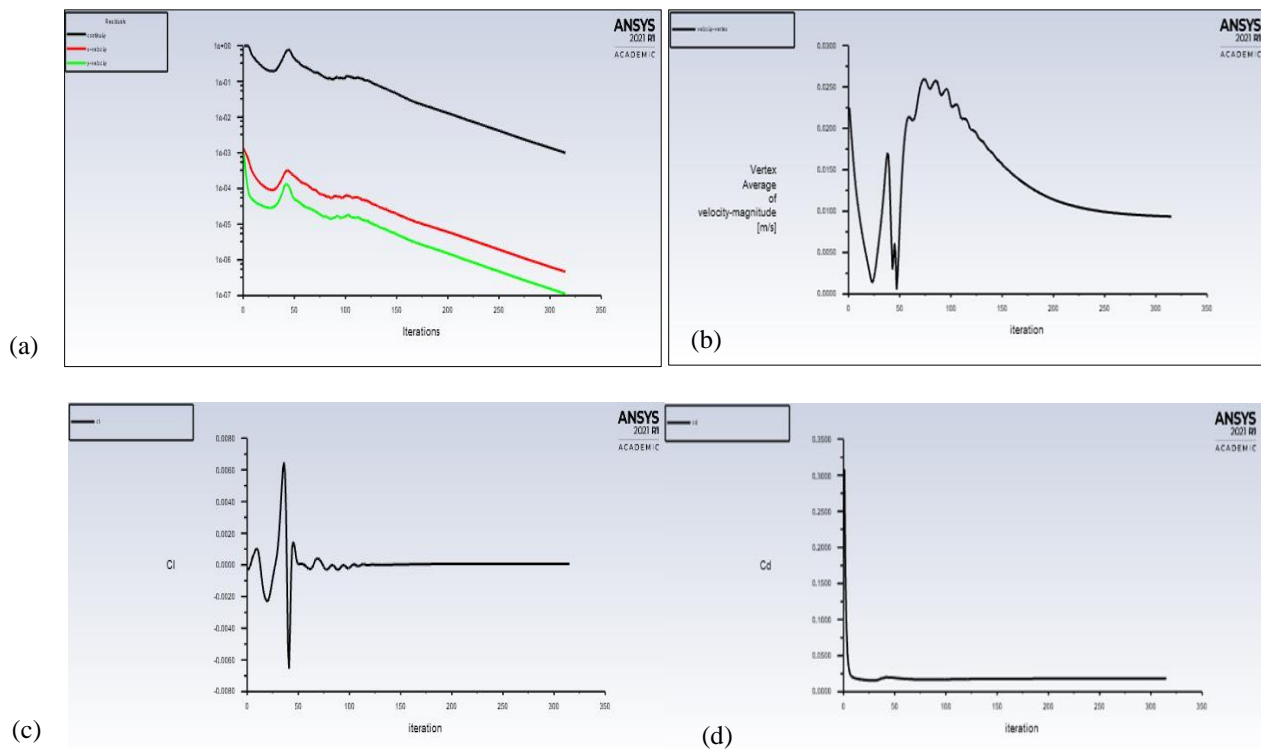

Figure 9 Convergence at steady state: (a) residuals, (b) velocity vertex average, (c) lift and (d) drag coefficients

Transient state flow simulations were carried out at different Reynold's number and the results are presented below:

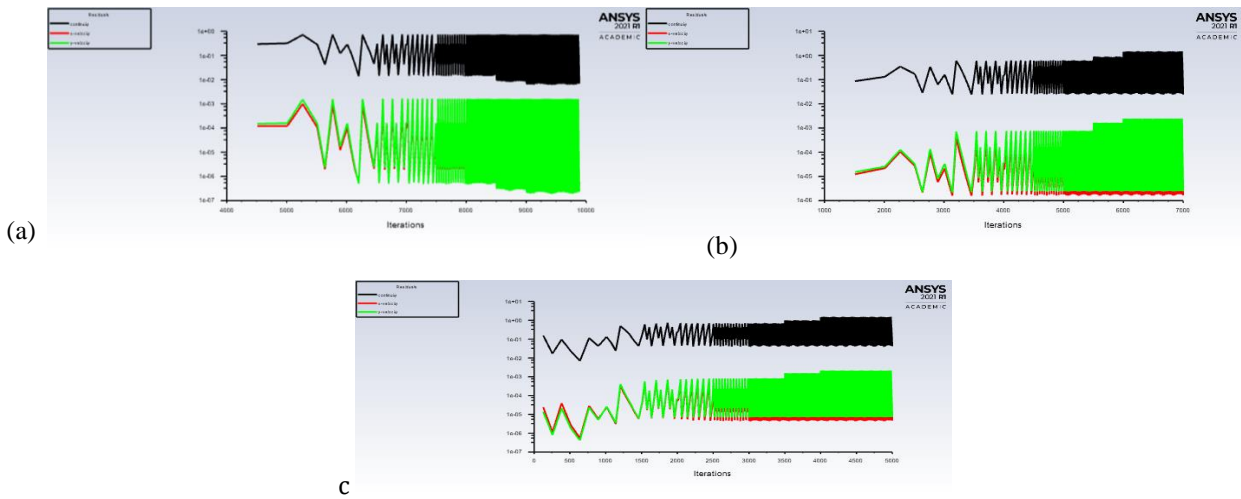

Figure 10 Residuals monitor plot at Reynold's number (a) 500, (b) 1000 and (c) 1400 respectively

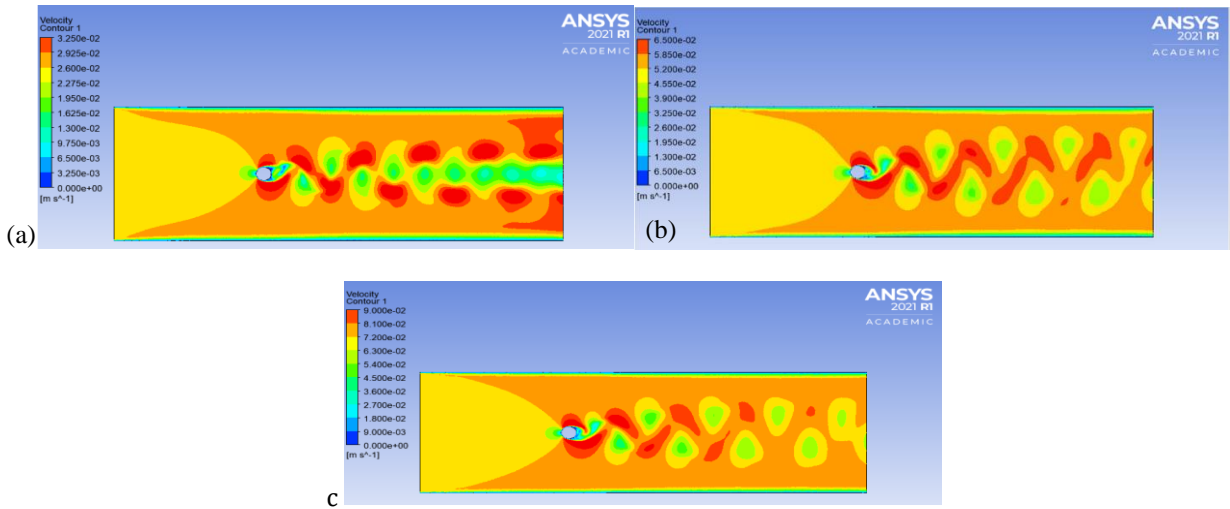

Figure 11 Vortex shedding at Reynold's number (a) 500, (b) 1000 and (c) 1400 respectively

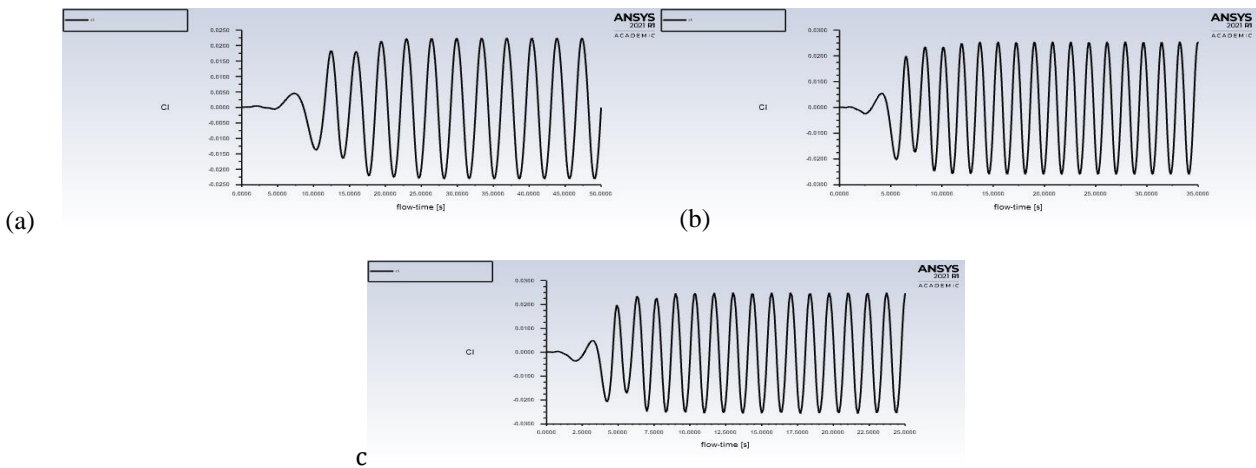

Figure 12 Lift coefficients at Reynold's number (a) 500, (b) 1000 and (c) 1400 respectively

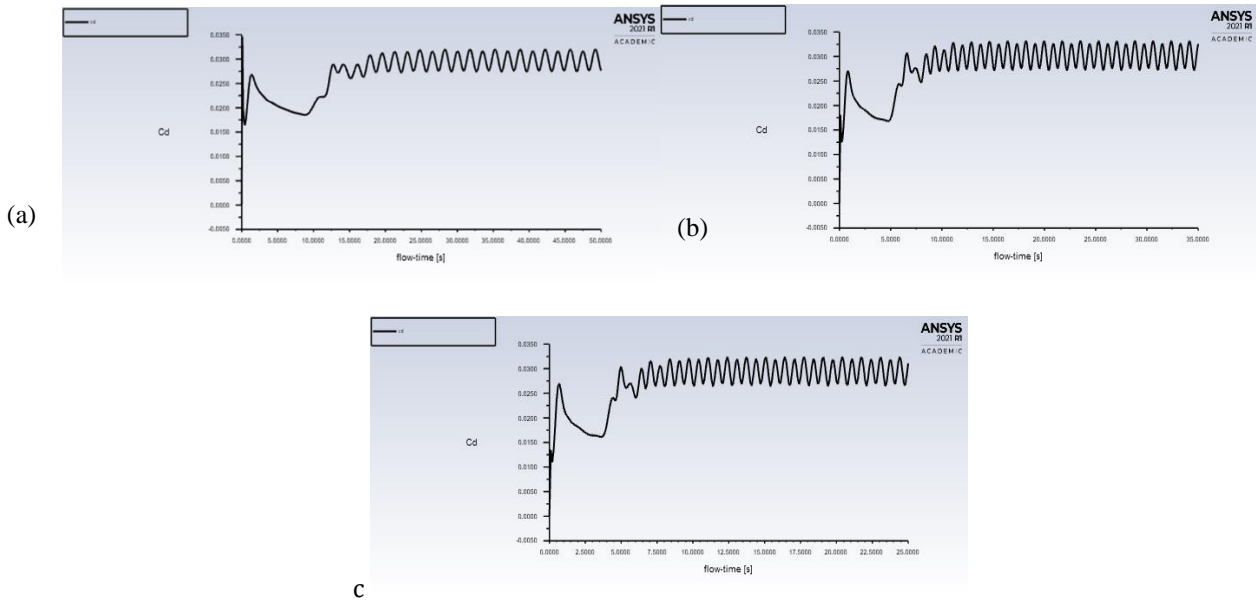

Figure 13 Drag coefficients at Reynold’s number (a) 500, (b) 1000 and (c) 1400 respectively

A summary of observations for the various flow scenarios is presented in table 3 below:

Table 3 Vortex Shedding and Lift at selected Reynold’s Numbers

REYNOLD’S NUMBER (RE _d)	INLET VELOCITY, U (m/s)	VORTEX SHEDDING	SINUSOIDAL LIFT
500	0.025	Yes	Yes
1000	0.05	Yes	Yes
1400	0.07	Yes	Yes

The frequency of vortex shedding is calculated from the oscillations of the velocity magnitude with time. The velocity monitor is set at a location 8cm from the centre of the cylinder along the x-axis.

By visual inspection of the velocity monitor, we can determine the number of waves, n, for a period of time, t, after convergence. The shedding frequency is then estimated as;

$$f = \frac{n}{t}$$

The plots of the vertex average of velocity monitor with time are shown below for the range of Reynold’s number:

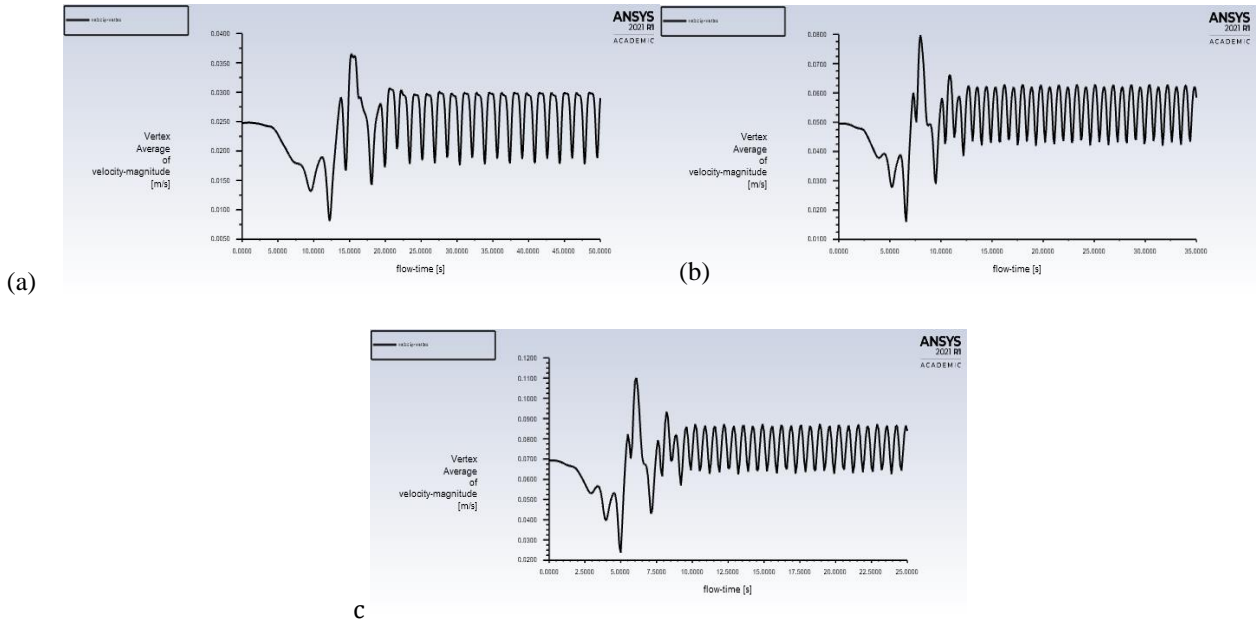

Figure 14 Velocity monitor plots at Reynold's number (a) 500, (b) 1000, (c) 1400 respectively

Using three characteristic velocities corresponding to Reynold's numbers 500, 1000 and 1400, we obtain the Strouhal number for each simulation, $C = \frac{fD}{U}$

The results are presented in table 4 below:

Table 4 Strouhal Numbers at selected Characteristic Velocities

VELOCITY, U (m/s)	NUMBER OF WAVES (n)	TIME (t)	FREQUENCY, $f = n/t$ (Hz)	STROUHAL NUMBER, $C = fD/U$
0.025	7.25	25	0.29	0.232
0.05	8.5	15	0.57	0.227
0.07	7.5	10	0.75	0.214

From the results presented, it can be observed that the frequency of vortex shedding increases with flow speed. Also, the Strouhal number is observed to be constant over the range of flow speeds. An average value of $C = 0.224$ is obtained.

Using Reynold's number of 1000, a constant temperature of 400K is imposed on the cylinder surface. We solve the energy equation in addition to the flow equations and study the effect on the vortex street and shear stress.

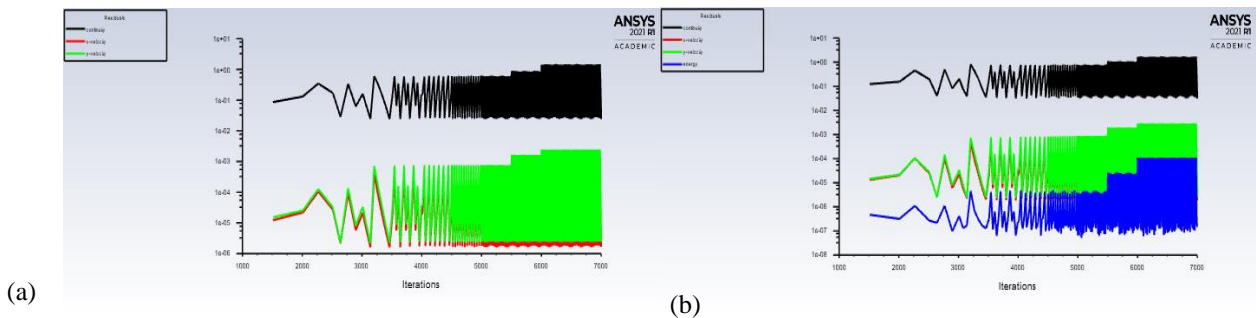

Figure 15 Residual plots for (a) adiabatic cylinder and (b) imposed surface temperature of 400K respectively

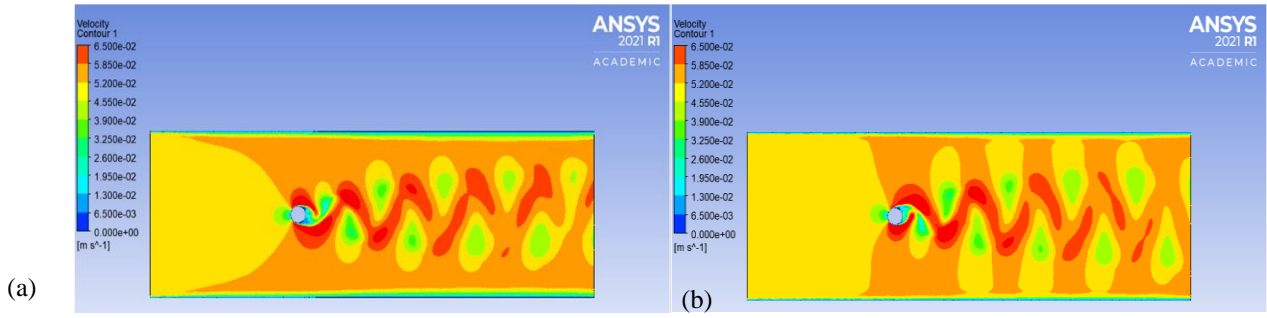

Figure 16 Vortex shedding for (a) adiabatic cylinder and (b) imposed surface temperature of 400K respectively

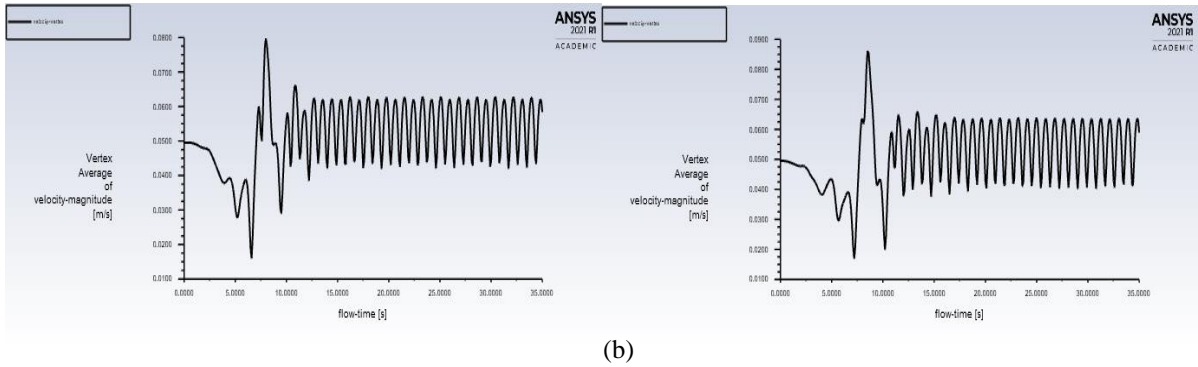

Figure 17 Velocity monitor plots for (a) adiabatic cylinder and (b) imposed surface temperature of 400K respectively

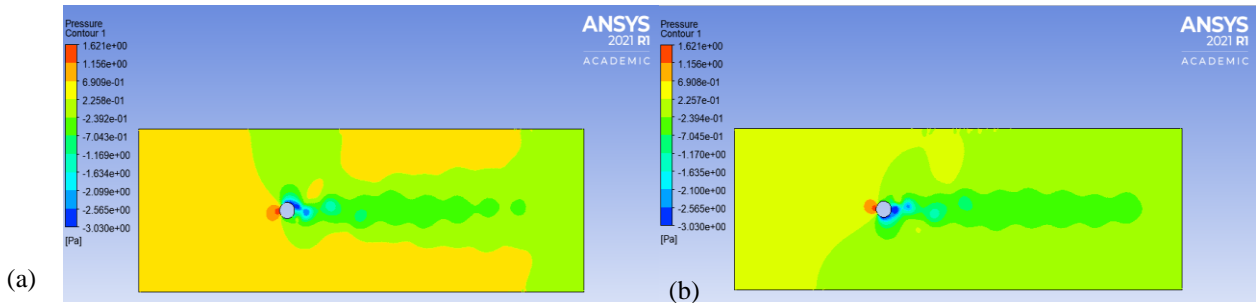

Figure 18 Pressure profile for (a) adiabatic cylinder and (b) imposed surface temperature of 400K respectively

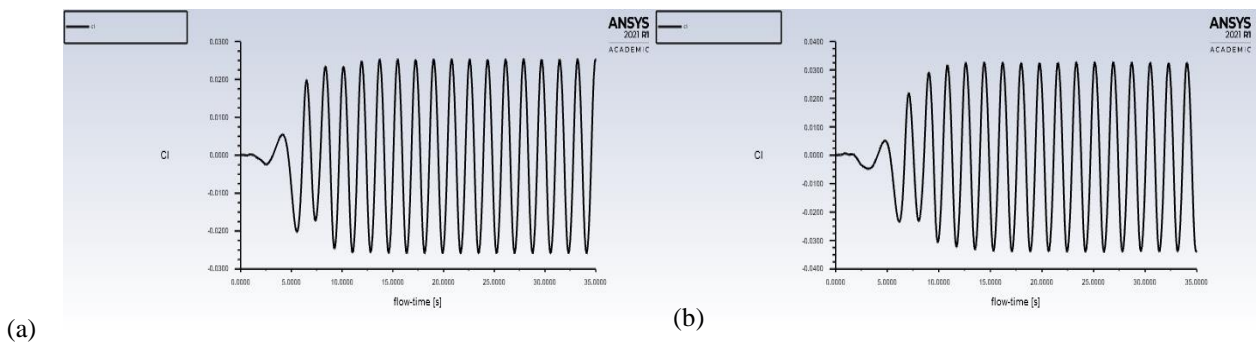
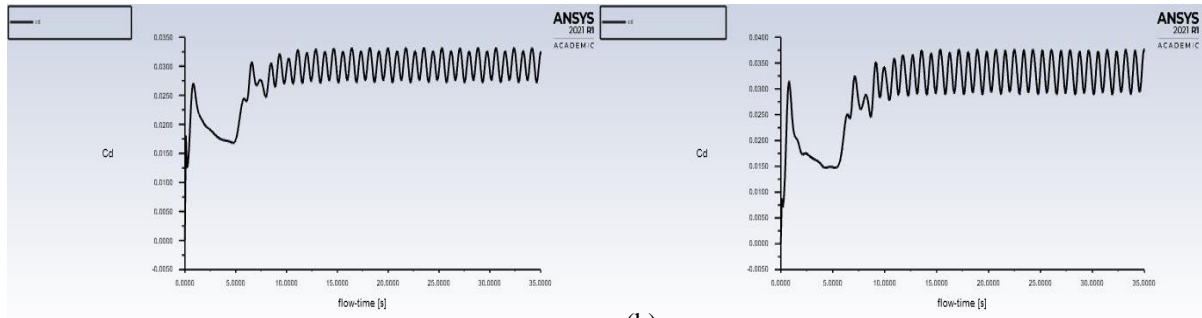

Figure 19 Lift coefficient for (a) adiabatic cylinder and (b) imposed surface temperature of 400K



(a) (b)

Figure 20 Drag coefficient for adiabatic cylinder and imposed surface temperature of 400K

A summary of observations is presented below:

- The flow takes a slightly longer time to converge for the imposed surface temperature case compared to the adiabatic cylinder.
- The frequency of vortex shedding is the same as the adiabatic cylinder, however, the magnitude of the shed vortices is slightly higher.
- The magnitude of lift and drag forces is higher than that on the adiabatic cylinder.
- This is due to local boiling of the water at the cylinder surface since water boils at 373K under atmospheric conditions.
- The pressure distribution shows generally lower pressure regimes than for the adiabatic cylinder.

The following methods, which are widely used in minimizing vibrations inside shell and tube heat exchangers, have been discussed under literature review:

- Use of Baffles/Support Plates
- Use of Impingement Devices at Entrance/Exit Areas
- Omission of Tubes at Critical vibration-prone Locations
- Proper selection of Tube Pitch/Layout Pattern
- Proper selection of Tube Material
- Choice of Tube Diameter
- Use of Anti-Vibration Technologies

Using the characteristic tube bank provided and as setup in the solution methodology with a pitch-diameter ratio (P/D) of 1.732 and flow at a Reynold’s number of 1000, the velocity profile, vertex average of velocity, drag and lift generation were monitored, and the plots are shown below:

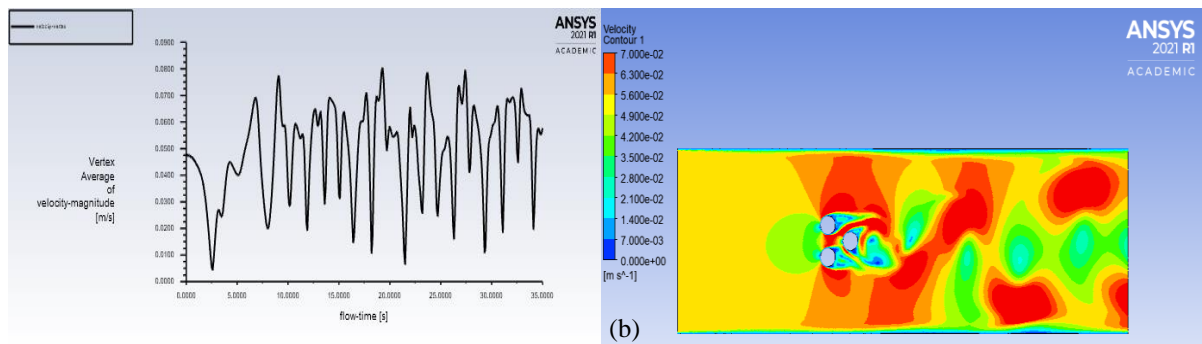

(a) (b)

Figure 21 (a) Velocity vertex monitor and (b) vortex shedding downstream of characteristic tube bank

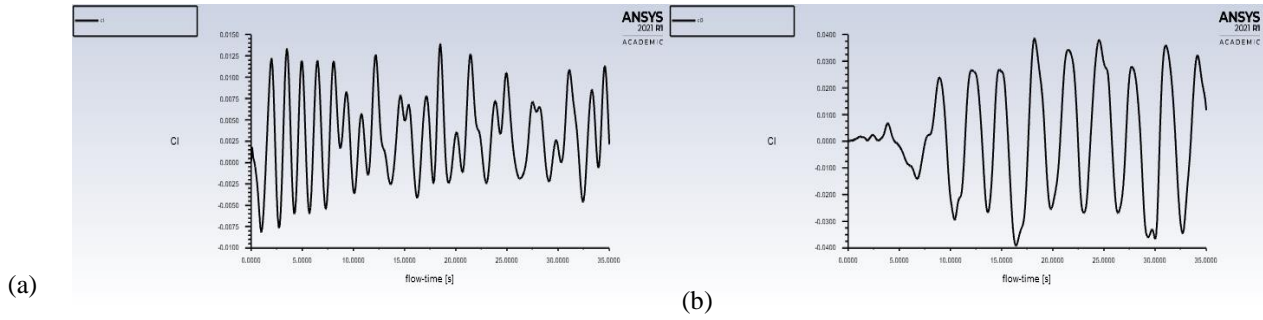

Figure 22 Lift coefficient profile for tubes in the (a) first and (b) second columns of characteristic tube bank respectively

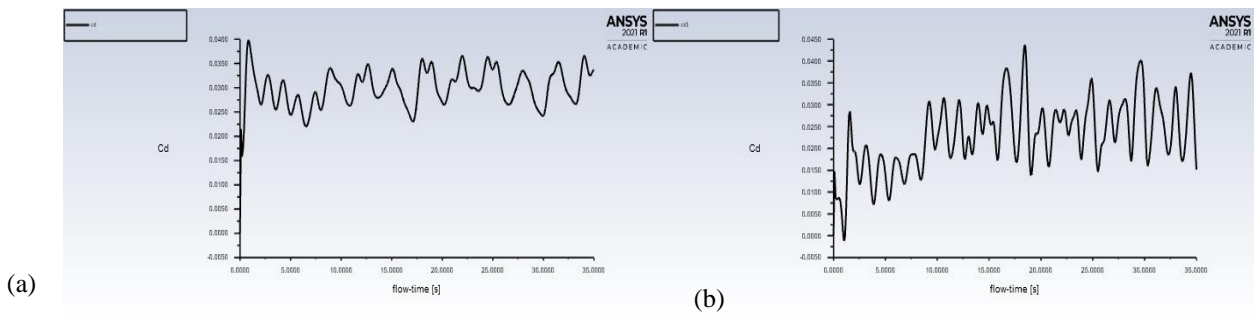

Figure 23 Drag coefficient profile for tubes in the (a) first and (b) second columns of characteristic tube bank respectively

The following observations are made:

- There is no noticeable vortex shedding immediately in the wake of the cylinders in the first column.
- Vortex shedding occurs downstream of the single tube in the second column. However, the pattern is not regular.
- The vortex formed away from the tube bank is of higher magnitude (combined effect from three tubes).
- The magnitude of sinusoidal lift force experienced by tubes in the first column is less than that on the second column.
- The magnitude of sinusoidal lift force experienced by the single tube in the second column is comparable to that observed for a single cylinder.
- It can be inferred that continuous tube arrays of the type used in this simulation is capable of minimizing vortex shedding, and by extension, vibrations inside heat exchangers.

6. Conclusion

From our study of flow over a single 2D cylinder for varying Reynolds number (Re_D) using a Transient solver with viscous-laminar modelling, we observed oscillatory behavior of flow and lift forces. This is due to vortex shedding downstream of the cylinder.

In each of the cases above, we also observe a boundary layer separation region known as the wake region. The pressure values in these wake regions were also observed to reach negative values.

The effects of temperature and variation of material properties on flow parameters were also studied. At a higher cylinder surface temperature of 400K, a slightly higher magnitude of vortex, lift and drag forces were observed. However, the vortex shedding frequency was the same in both cases.

In the case of multiple cylinders, using a characteristic 3-tube array, it is observed that vortex shedding does not immediately occur in the wake of the first column of cylinders. However, the effects are noticeable further downstream of the single cylinder in the second column.

This study suggests that the use of multiple tubes in a well-layered array can minimize vortex shedding inside a heat exchanger. The spacing of the adjacent tubes (pitch to diameter ratio) is also a critical factor in designing a shell and tube heat exchanger.

References

- [1] Blevins, R. D. (1990) *Flow-Induced Vibration*, 2nd edn., Van Nostrand Reinhold
- [2] Gelbe, H, Jahr, M, Schröder, K. Flow-induced vibrations in heat exchanger tube bundles. *Chem Eng Process* 1995; 34: 289–298.
- [3] Chen, S. S. (1990) *Flow-Induced Vibration of Circular Cylindrical Structures*, Hemisphere
- [4] Dole, R., et al. "Mitigate vibration issues in shell-and-tube heat exchangers." *Hydrocarbon Processing*, Dec. 2015. Gale Academic OneFile
- [5] Anagnostopoulos, P., Computer-Aided Flow Visualization and Vorticity Balance in The Laminar Wake of a Circular Cylinder, *Journal of Fluids and Structures* (1997) 11 , 33 – 72
- [6] Mohammed J. Mawat, Simulation of Cylindrical Body Structure Subjected to Flow in Different Reynolds Number Regimes, *Muthanna Journal of Engineering and Technology (MJET)*, 6-1-(2018) 45-51
- [7] Dhananjay Yadav, Ritesh Srivastava, Jinho Lee, Numerical Simulation of Vortex Shedding Past a Single Cylinder Confined in a Channel, *Fluid Mechanics*. Vol. 1, No. 1, 2015, pp. 1-4
- [8] Antoine Placzek, Jean-François Sigrist, Aziz Hamdouni, Numerical Simulation of Vortex Shedding Past a Circular Cylinder in a Cross-flow at Low Reynolds Number with Finite Volume Technique – Part 2: Flow-Induced Vibrations, *American Society of Mechanical Engineers, Pressure Vessels and Piping Division (Publication) PVP* · July 2007