



(RESEARCH ARTICLE)



Transmission system with adaptive LDPC-Coded OFDM modulation implemented in GNU Radio

Zsolt Alfred Polgar, Mihai Stef and Mate-Martón Mezei *

Communications Department, Electronics, Telecommunications and Information Technology, Technical University of Cluj-Napoca, Romania.

International Journal of Science and Research Archive, 2024, 13(02), 2080–2088

Publication history: Received on 27 October 2024; revised on 04 December 2024; accepted on 06 December 2024

Article DOI: <https://doi.org/10.30574/ijrsra.2024.13.2.2405>

Abstract

Real-time testing in wireless channel conditions of Forward Error Correction (FEC) coding techniques, Modulation and Coding Scheme (MCS) selection algorithms is a complex and challenging task. GNU Radio and Software Defined Radio (SDR) concept allow a wide range of practical and low-cost solutions to perform the testing operations mentioned above. The paper proposes a duplex transmission system with adaptive LDPC (Low Density Parity Check) coding and OFDM (Orthogonal Frequency Division Multiplexing) modulation implemented in GNU Radio. The frame structure, design principles, system architecture, and mechanisms controlling the transmission process are presented. The system's modular architecture provides the framework for testing various LDPC coding and MCS selection techniques. The system's design allows us to maximize the transmission's efficiency, the encapsulation of various data structures, i.e., frame and transport block, using reduced overheads and the necessity of padding operations is minimized.

Keywords: Adaptive modulation; Communication protocol; GNU Radio; LDPC codes; SDR; System architecture

1. Introduction

Forward Error Correction (FEC) coding combined with Orthogonal Frequency Division Multiplexing (OFDM) modulation is the primary transmission technique in high-speed communication networks. Some networks, such as 802.11a [1], used convolutional codes, while more recent networks use more powerful FEC codes. Turbo codes are used in 4G networks [2], whereas Low Density Parity Check (LDPC) codes are used in networks like WLAN 802.11n [1], WiMAX 802.16e [3], and 5G [2]. The LDPC codes exhibit excellent threshold performance and facilitate parallel implementation, which allows them to meet low latency and high throughput requirements [4]. An overview of the channel FEC coding for 5G NR (New Radio) networks is presented in [2]. This paper shows that LDPC codes support high throughput, variable coding rate, and Hybrid Automatic Repeat reQuest (HARQ).

Wireless transmissions must employ Link Adaption (LA) techniques to fulfill various Quality of Service (QoS) requirements. An analysis of LA techniques and the challenges generated by these techniques in the context of 5G NR is presented in [5]. Adaptive Modulation and Coding (AMC) is the most used and efficient among the different LA techniques. Its efficiency can be increased if combined with other LA techniques, as proposed in [5]. Solutions for enhancing the efficiency of AMC-based LA in the context of LTE/LTE-A networks are proposed in [6]. Cross-layer and Markov decision process techniques are proposed to improve the AMC-based LA. Some researchers [7] suggested using reinforcement learning to select the best MCS to maximize the system's spectral efficiency while maintaining a low Block Error Rate (BLER). The use of AMC schemes requires rate selection and matching operations. Shortening and puncturing operations, as described in [1], are used for rate selection, and if HARQ is used, rate matching should be applied, as presented in [2] [8].

* Corresponding author: Mate-Martón Mezei

In several papers, researchers reported implementing LDPC-coded OFDM systems on Software Defined Radio (SDR) platforms to evaluate the coded modulations more realistically than computer simulations. In [9], the implementation of the transmission on the downlink shared data channels of the 5G NR on SDR platforms is presented. The designed system evaluates the LDPC code's performance in simulated and field trial conditions. Researchers [10] considered combining LDPC codes with MIMO techniques to improve the reliability and capacity of transmissions for massive connectivity. The system was implemented and tested in SDR platforms, and the performance improvements obtained on Rayleigh faded channels are reported. In [11], the authors present a prototype implementation of the uplink shared data channel in 5G NR. Computer simulations were used for performance evaluation in Rayleigh faded multipath wireless channels. The developed signal processing may be used for SDR implementations of the 5G NR physical layer.

This paper proposes the frame structure, architecture, and design of a duplex transmission system using LDPC-coded OFDM modulation with adaptive MCS selection implemented in GNU Radio. The paper also proposes the protocol that controls the adaptive coding and decoding operations and the building and handling of the data frames transporting the coded bits. The performance of the developed system was evaluated using simulations in GNU Radio. The proposed SDR platform can be used to test and assess various LDPC coding/ decoding and MCS selection algorithms in simulated and real channel conditions. The paper's structure is as follows: Section 2 presents the proposed frame structure and system architecture, discusses the design aspects, and presents the protocol developed to control the coding and decoding operations. Section 3 gives some system evaluation, and Section 4 concludes the paper.

2. System Architecture and FEC Mechanisms

Fig. 1 shows the structure of the data frames used to carry the LDPC-coded and OFDM-modulated data, and Fig. 2 shows the simplified architecture of the implemented system. The proposed architecture extends an example OFDM system integrated into GNU Radio [12] without adaptive transmission capabilities and an OFDM system with adaptive modulations [13]. This section (and Fig. 2) focuses on the processing blocks dealing with the adaptive modulation and coding at the transmitter and receiver side. Details about other functional blocks of the implemented transmission system, such as synchronization, equalization, header stream, data stream multiplexing and demultiplexing, etc., can be found in [12] and [13]. The parameters of the considered OFDM modulation are 64 subcarriers, 11 null subcarriers at the frequency band edges, null DC subcarrier, and 4 pilot subcarriers, 25% cyclic prefix. These parameters are like the ones used by the 802.11 networks [1] in 20MHz wide frequency bands.

2.1. Frame Structure and Design Aspects

The design guidelines are the following:

- High spectral efficiency
- Good synchronization capabilities
- Low delay due to buffering operations
- Increased flexibility in selecting the FEC code
- Transport of data streams with various characteristics.

As seen in Fig. 1., a two-level framing structure is used to fulfill these requirements. The LDPC codewords are loaded in Transport Blocks (TBs), which can carry one or several codewords. The TB has no separate header. The control information concerning the TB has been included in the header of the OFDM frames. Each TB includes a 32-bit CRC (Cyclic Redundancy Check) used to validate the correctness of the decoded bits. The length (in bits) of a TB should be larger than the capacity of an OFDM frame to ensure that there is a single transition from one TB to another during an OFDM frame. This condition is imposed by the reduced control information used for TB. It does not set an upper limit on the TB length, but it should extend, if possible, on a small number of OFDM frames, if possible, less than 2. The CQI estimation is performed at the frame level, and if the TB extends over many frames, the CQI can change significantly, and the MCS selection algorithm will become more complex.

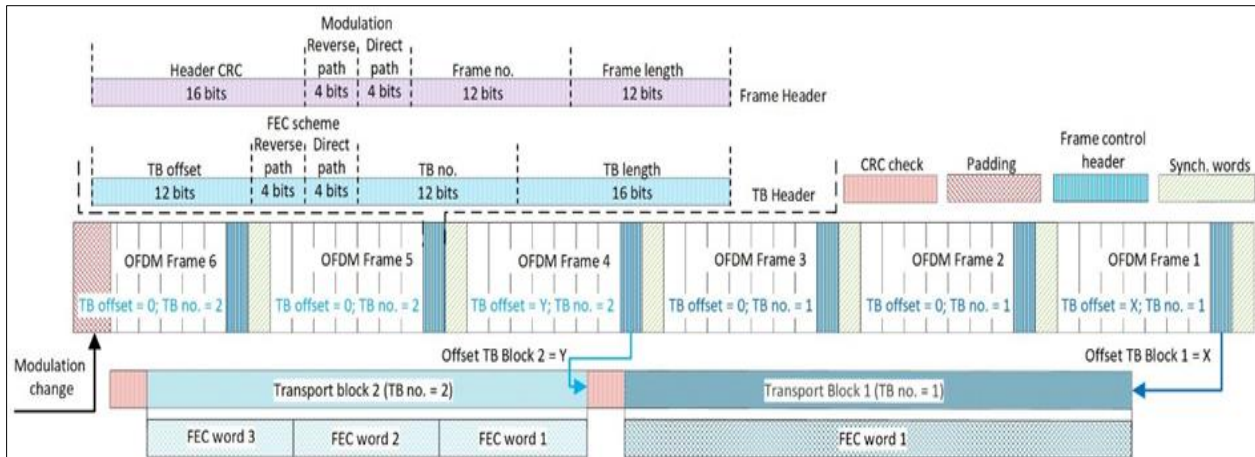

Figure 1 The structure of the OFDM frames and of the FEC transport blocks

The OFDM frame in the designed system includes 20 OFDM symbols, and the header is composed of 3 OFDM symbols if FEC coding is not used and 4 OFDM symbols if FEC encoding is used. The number of symbols in the OFDM frame should be large enough to provide high spectral efficiency (in our setup, it is higher than 83%) but also to ensure good synchronization and channel transfer function estimation. Two special OFDM symbols, Sync word 1 and Sync word 2 [12] [14], are included in the frame header for synchronization and channel estimation purposes; these operations are performed once per frame, which limits the length of the frame (in OFDM symbols). The size of the frame should be smaller, even much smaller, than the coherence time of the channel for good channel estimation.

As mentioned above, the proposed structure of the OFDM frame control header comprises two OFDM symbols using BPSK modulation. The first OFDM symbol, i.e., 48 bits, is the frame control header, while the second symbol, also carrying 48 bits, is the TB control header. The structure of the OFDM frame control header in the case of a full duplex transmission system is the following (see Fig. 2):

- Frame Length in bytes: 12 bits; it is possible the representation of large frame sizes on a small number of bits
- Frame Number: 12 bits; large no. of frames is possible
- Modulation Constellation Direct Path: 4 bits
- Modulation Constellation Reverse Path: 4 bits
- Header CRC: 16 bits; good error detection capabilities.

The structure of the TB control header in the case of a full duplex transmission system is the following (see Fig. 2):

- TB Length in bits (only info. bits): 16 bits; it is possible the use of long LDPC codewords, i.e., powerful codes
- TB Number: 12 bits; large no. of TBs
- FEC Scheme Direct Path: 4 bits
- FEC Scheme Reverse Path: 4 bits
- TB Offset: 12 bits; a wide range of offset values is possible.

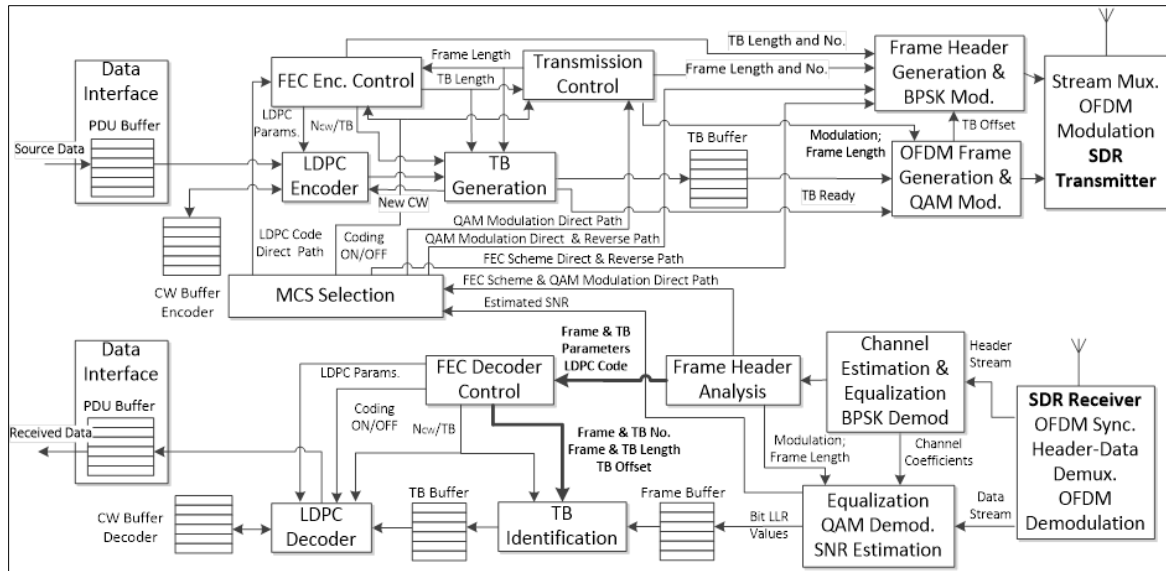

Figure 2 The simplified architecture of the duplex OFDM transmission system with adaptive LDPC-code OFDM modulation

The TB offset establishes the positioning of the TB inside the OFDM frame and has a nonzero value only in frames where a new TB starts – see Fig. 1. The modulation constellation should be constant during a TB. If the modulation should change, the new TB will begin in the next frame, and zero padding is inserted in the current one – see Fig. 1.

The implemented system, in its current form, doesn't perform rate-matching operations. Still, it is imposed the condition to transmit all the data bits stored in the input data buffer, see Fig. 2. If at a given moment the number of bits in the input buffer is smaller than the information length of the used codeword then shortening operation will be performed as described in [1]. This solution is better than using zero padding, with higher transmission efficiency. Puncturing operation [1] must be performed to keep the coding rate constant, but this is not implemented in our system.

If the length of the codeword is LCW bits and the capacity in bits of the OFDM frame is FC , then a TB will include $NCW = 1 + \lceil FC / LCW \rceil$ codewords and the information bits will be spread over these codewords. A 32-bit CRC is attached to the information bits in the NCW codewords, and the entire data structure, i.e., information and CRC bits, is applied to the LDPC coder. The length of the TB information part should be reduced to accommodate the 32 CRC bits.

2.2. FEC Functional Blocks and Processes

The LDPC encoding and framing algorithms are performed by three main blocks of the implemented OFDM transmission system: the LDPC Encoder block, the TB Generation block, and the OFDM Frame Generation block. The FEC Encoder Control and Transmission Control blocks configure the blocks performing the coded transmission. Fig. 2 depicts the information exchange between the above-mentioned blocks. Fig. 3 presents the operations performed to encode the data and generate the data structures necessary for transmission. In the first step, 'Acquire Parameters,' the information from the reverse path header concerning the used code and modulation on the direct path is transferred to the mentioned control blocks. In the second step, 'Configuration,' the FEC Encoder Control block selects the FEC scheme, computes the no. of payload bits in a codeword and the no. of codewords in a TB, and configures the LDPC Encoder and the TB Generation blocks. The Transmission Control block configures the modulation scheme of the OFDM data subcarriers. The 'LDPC encoding' and the 'TB generation' processes go together. Once a codeword is available, a permutation process is performed, and shortening is performed if necessary. Subsequently, the codeword is placed in the TB buffer. The LDPC encoding algorithms used in the system perform a permutation of the H matrix to generate a coding G matrix with a triangular shape $[P \ I]$ [14], I is the identity matrix. In order to facilitate the optimization of codeword lengths, it is essential to revert the H matrix to its original form. The last process, 'OFDM frame generation,' is performed by the OFDM Frame Generation block, which loads the TB in the OFDM frames and selects the offset of the TB in the frame. This block also inserts padding to ensure a constant stream of frames when TBs are missing (no payload to transport) or when the MCS is changed. The length of the OFDM frame is given in bytes, resulting in a smaller number of bits for the frame header. However, the length of the LDPC codewords and of the TBs should be specified in bits. Due to this, loading the TBs in the frames requires more complex alignment operations, which increases the overall complexity of the OFDM frame generation process.

The Frame Header Generation block receives all control information for the direct and reverse paths, computes the CRC check of the header, and builds the frame header. It also appends to the header the synchronization words.

At the receiver side, the FEC Decoder Control block configures the LDPC Decoder and TB Identification blocks based on the information extracted from the control header received on the reverse path. The information exchange between the blocks involved in the decoding process is depicted in Fig. 2. Fig. 4 shows the processing steps for extracting TBs from the OFDM frames. The TB Identification block does this processing and prepares the TBs in the receiver TB Buffer, which will be applied to the LDPC Decoder block. The LDPC code permutation, i.e., the inverse of the permutation done at the transmission side, is also performed in the TB extraction process. Fig. 5 shows the operations of the LDPC decoding process. In the buffers of the reception chain (see Fig. 2), the Log Likelihood Ratios (LLRs) [15] of the received bits computed by the QAM demodulator are stored.

The SNR on the reverse path is estimated using the equalized pilot subcarriers, as presented in [13]. The MCS Selection block selects the LDPC code and the modulation on the reverse path by comparing the estimated SNR with some imposed thresholds. More performant MCS selection algorithms can be used, as proposed in [5] [6] [7].

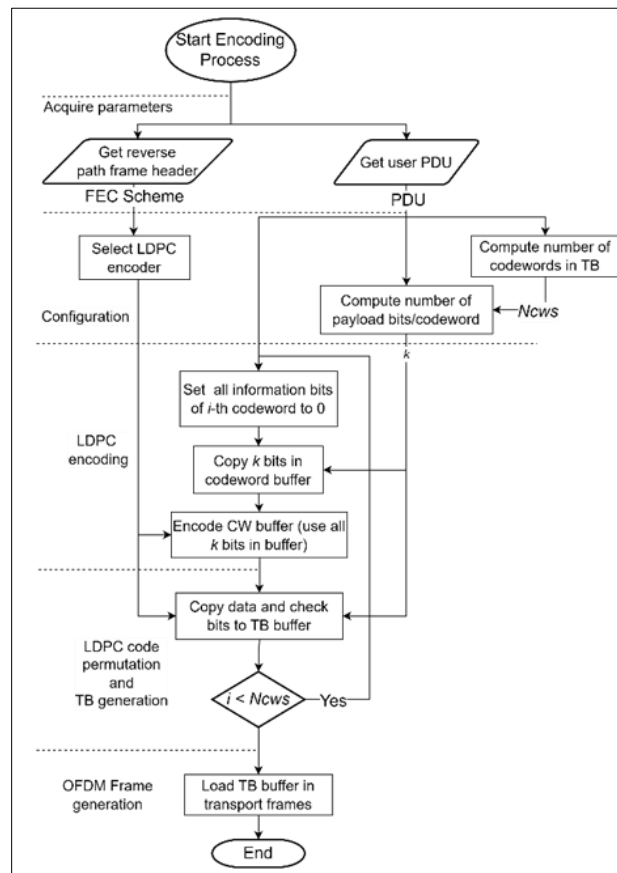

Figure 3 The TB extraction process from the OFDM frames

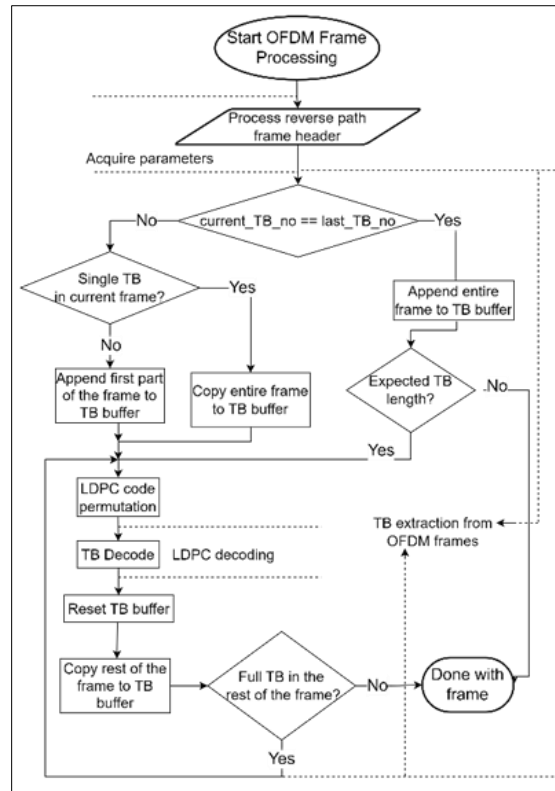

Figure 4 The FEC encoding and framing processes

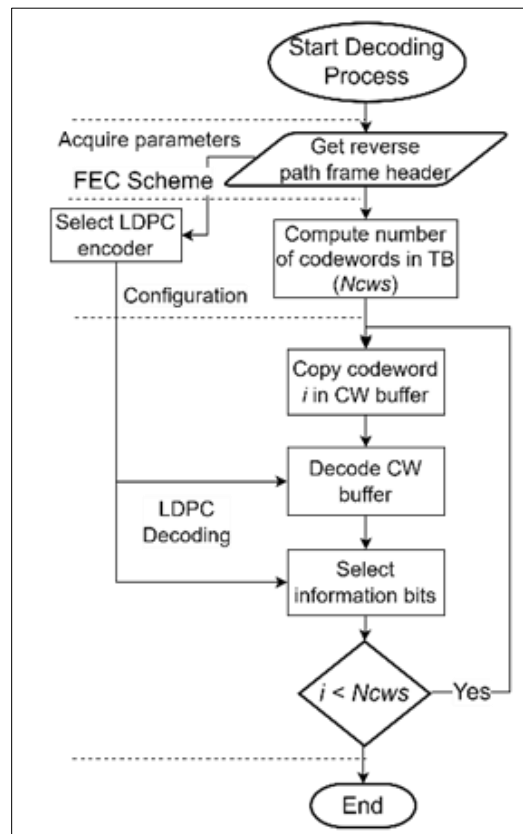

Figure 5 The FEC decoding process

3. Results and discussion

This section presents the results of several experiments that aim to show the functioning of the developed transmission system with adaptive LDPC-coded OFDM modulations. The performance analysis of the LDPC-coded OFDM modulation is beyond the scope of this paper.

With the imposed parameters, i.e., frame of 20 OFDM symbols, 48 data subcarriers, QPSK, 8PSK, and 16QAM modulations, TB length < 2×Frame length, the length of the LDPC codes is between hundreds of bits and 7680 bits, which offers a relatively wide range of code lengths. If necessary, the TB length can be extended beyond the 2×Frame length limit.

In Fig. 6 are presented some statistics obtained during a test with an LDPC code having the parameters: n=300 (codeword length), k=152 (no. info bits), R=0.5 (coding rate). The channel is affected by a slow fading with an imposed distribution and the noise was selected to induce variations in the modulation scheme. The code was kept constant during the experiment. It can be seen that the system is changing the modulation scheme based on the estimated SNR and that the TB error rate is kept relatively constant with the change of the channel's SNR. It can be observed that the number of iterations required by the LDPC decoder increases with the utilization of higher-order modulations, which are more susceptible to the effects of noise.

The throughput, Thr, of the system is given by:

$$Thr = N_d \cdot n_j \cdot \frac{f_{sOFDM}}{(1+U) \cdot N_{FFT}} \cdot R_c \cdot \frac{N_{syd}}{N_{syf}} \cdot \eta_{Tb} \cdot (1 - T_{ber}) \dots\dots\dots (1)$$

where N_d is the no. of data subcarriers, n_j is the no. of bits/symbol for modulation scheme j , f_{sOFDM} is the OFDM sampling frequency, U is the fraction of the cyclic prefix from the OFDM symbol, N_{FFT} is the no. of points in which the IFFT/FFT are computed for OFDM modulation, R_c is the coding rate, N_{syd} is the no. of data OFDM symbols in the frame, N_{syf} is the total no. of OFDM symbols in the frame, η_{Tb} is the TB efficiency and T_{ber} is the TB error rate.

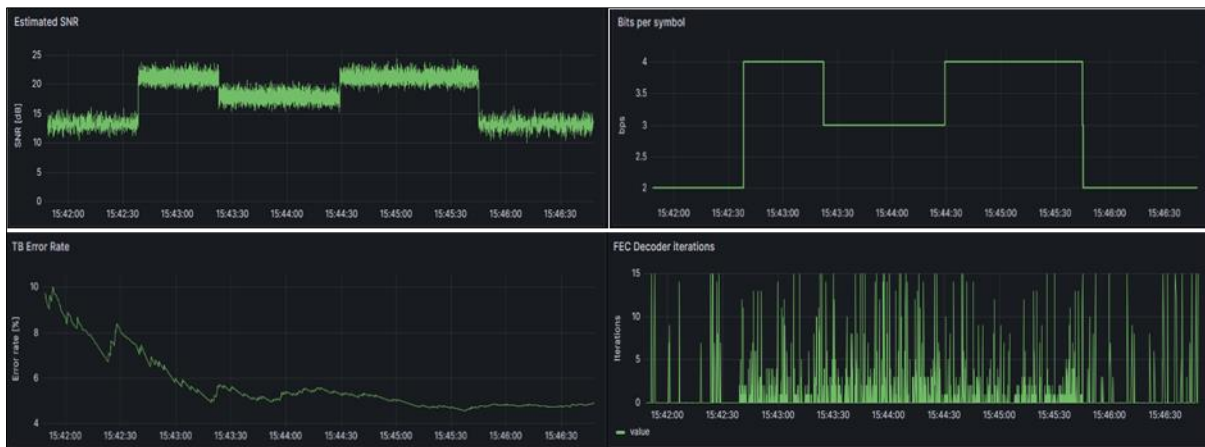

Figure 6 Experimental testing of the modulation scheme adaptation, FEC decoding operations

By considering the OFDM modulation and frame parameters given in Section II, a sampling frequency $f_{sOFDM}=100\text{kHz}$, a 16QAM modulation, i.e., $n_j=4$, an ideal channel, i.e., $T_{ber}=0$, a TB efficiency $\eta_{Tb}\approx 1$, the throughput Thr will be $\approx 200\text{kbps}$ for the uncoded transmission and $\approx 100\text{kbps}$ for a coding rate $R_c=0.5$ and $\approx 68\text{kbps}$ for $R_c=0.34$. The throughput for the above-mentioned three cases was measured using the *iPerf3* tool and the obtained results are close to the theoretical values.

The conducted assessments indicate that the system operates effectively, with all components—including framing, modulation and demodulation, channel estimation, equalization, and FEC coding and decoding—functioning as intended. Consequently, the system is adequately prepared for the evaluation of a variety of adaptive modulation and coding techniques.

The code implementing the described transmission system is given in [16] and some related documentation can be found in [17].

4. Conclusion

The paper proposes the architecture of a duplex OFDM transmission system with adaptive selection of the FEC codes and subcarrier modulation. The system's primary purpose is to provide a scalable and flexible framework for testing various adaptive coding and modulation schemes in realistic situations, i.e., simulated, or real wireless channel conditions and real data traffic, using the GNU Radio environment and SDR interfaces. Different FEC coding and MCS selection algorithms can be integrated easily into the system without modifying the framing and signaling operations. The system can also be used for teaching purposes, making real-time tracking of the adaptive coding and modulation operations and other processing from the OFDM transmission chain possible.

In terms of future research directions, it is pertinent to highlight the need for comprehensive testing of the system employing a variety of LDPC codes under both simulated and real-world wireless channel conditions. Additionally, investigating the performance of different MCS selection algorithms within these varied channel conditions would provide valuable insights into the system's robustness and adaptability.

Compliance with ethical standards

Disclosure of conflict of interest

No conflict of interest to be disclosed.

References

- [1] IEEE Std 802.11, Part 11: Wireless LAN Medium Access Control (MAC) and Physical Layer (PHY) Specifications, 2020.
- [2] X. Li and Z. Xu, "A LDPC Encoding and Decoding Scheme of Low Complexity Applied to Physical Layer 802.16e," 2012 International Conference on Industrial Control and Electronics Engineering, Xi'an, China, 23-25 August 2012, pp. 723-726.
- [3] J.H. Bae, A. Abotabl, H-P. Lin, K-B. Song and J. Lee, "An overview of channel coding for 5G NR cellular communications," APSIPA Transactions on Signal and Information Processing, vol. 8, pp. 1-14, 2019.
- [4] Y. Zhang, K. Peng, X. Wang and J. Song, "Performance analysis and code optimization of IDMA with 5G new radio LDPC code," IEEE Communications Letters, vol. 22, no. 8, pp. 1552-1555, Aug. 2018.
- [5] F. J. Martín-Vega, J. C. Ruiz-Sicilia, M. C. Aguayo and G. Gomez, "Emerging Tools for Link Adaptation on 5G NR and Beyond: Challenges and Opportunities," IEEE Access, vol. 9, pp. 126976-126987, 2021.
- [6] A.A. Bin-Salem, TC. Wan, H. Naeem, et al. "Efficient models for enhancing the link adaptation performance of LTE/LTE-A networks," J Wireless Com Network, vol. 10, 2022.
- [7] M. P. Mota, D. C. Araujo, F. H. Costa Neto, A. L. F. de Almeida and F. R. Cavalcanti, "Adaptive modulation and coding based on reinforcement learning for 5G networks," 2019 IEEE Globecom Workshops (GC Wkshps), Waikoloa, HI, USA, 2019, pp. 1-6.
- [8] F. Hamidi-Sepehr, A. Nimbalkar and G. Ermolaev, "Analysis of 5G LDPC codes rate-matching design," 2018 IEEE 87th Vehicular Technology Conference (VTC Spring), Porto, Portugal, 3-6 June 2018, pp. 1-5.
- [9] W. Ji, Z. Wu, K. Zheng, L. Zhao and Y. Liu, "Design and Implementation of a 5G NR System Based on LDPC in Open Source SDR," 2018 IEEE Globecom Workshops (GC Wkshps), Abu Dhabi, United Arab Emirates, 9-13 Dec. 2018, pp. 1-6.
- [10] R. Prieto, A. Abril and A. Ortega, "Experimental Alamouti-STBC using LDPC codes for MIMO channels over SDR systems," 2017 IEEE 30th Canadian Conference on Electrical and Computer Engineering (CCECE), Windsor, ON, Canada, 30 Apr. – 3 May 2017, pp. 1-5.
- [11] G. Cisek and T. P. Zielinski, "Prototyping software transceiver for the 5G New Radio physical uplink shared channel," 2019 Signal Processing Symposium (SPSympo), Krakow, Poland, 17-19 Sept. 2019, pp. 150-155.

- [12] GNU Radio Manual and C++ API Reference 3.9.4.0, OFDM Blocks, available at: www.gnuradio.org/doc/doxygen/group_ofdm_blk.html, accessed on: Jan. 25, 2024.
- [13] Z. A. Polgar and M. Stef, "OFDM transceiver with adaptive modulation implemented in GNU Radio," 2023 46th International Conference on Telecommunications and Signal Processing (TSP), Prague, Czech Republic, 12-14 July 2023, pp. 37-42.
- [14] Low Density Parity Check Codes. Available online: www.staff.ncl.ac.uk/r.carrasco/MSc%20DataComms%20Tutorial.ppt (accessed on 31 Jan. 2024)
- [15] G. Hosoya and H. Yashima, "Log-likelihood ratio calculation for iterative decoding on rayleigh fading channels using pade approximation," Journal of Applied Mathematics, vol. 2013, article ID 970126.
- [16] Adaptive OFDM modem and monitoring library in GNU Radio. Available online: <https://github.com/mihaipestef/gr-dtl> (accessed on 12 Dec. 2023).
- [17] Grafana documentation. Available online: <https://grafana.com/docs/grafana/latest/> (accessed on 24 Nov. 2023).